

VersaSTUDIO

BN-20D

Manual for Switching to S-PG2 Ink

Contents

Contents.....	1
Overview	2
Introduction.....	2
Checks before Operations	3
Items Required	3
Switching to S-PG2 Ink.....	4
Step 1: Updating the Firmware.....	4
Step 2: Downloading the BN-20D Driver and Utility Installer.....	5
Step 3: Installing BN-20D Driver and Utility	5
Step 4: Checking the Firmware Version.....	6
Step 5: Performing a Nozzle Drop-out Test.....	6
Step 6: Replacing the Drain Cartridge.....	8
Step 7: Fill with S-PG2 ink.....	8
Step 8: Replacing Parts for Maintenance	9
Step 9: Performing a Nozzle Drop-out Test.....	10
Step 10: Registering the BN-20D in VersaWorks Again.....	11

Overview







Introduction

Thank you very much for purchasing the Roland BN-20D. This manual explains the procedure for replacing the S-PG ink currently used in the BN-20D with S-PG2 ink.

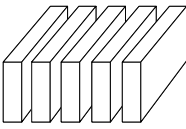
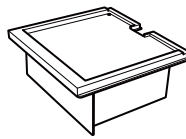
If you cannot carry out work according to the procedures in this manual or if unexpected problems occur during work, contact your authorized dealer.

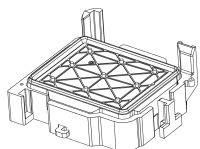
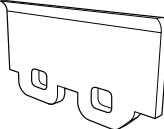
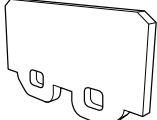
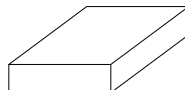
Checks before Operations

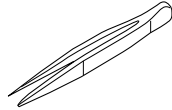
Items Required

 <p>S-PG2 ink cartridges</p>	 <p>Drain cartridge</p>	 <p>Cleaning stick</p>	 <p>S-PG2-CL cleaning liquid</p>	 <p>Cap top</p>
 <p>Wiper</p>	 <p>Felt wiper</p>	 <p>Wiper pad</p>	 <p>Gloves</p>	 <p>Tweezers</p>
 <p>Protective eyewear</p>				

Switching to S-PG2 Ink

Step 1: Updating the Firmware

The firmware must be updated only when switching to S-PG2 ink.

CAUTION

Updating the firmware when continuing to use S-PG ink may cause a malfunction or failure. If the firmware is updated accidentally while still using S-PG ink, contact your authorized dealer.

Procedure

- 1 Start [Roland DG Connect Hub].
- 2 In the main window, select the machine to use.
- 3 Click [Firmware Update].

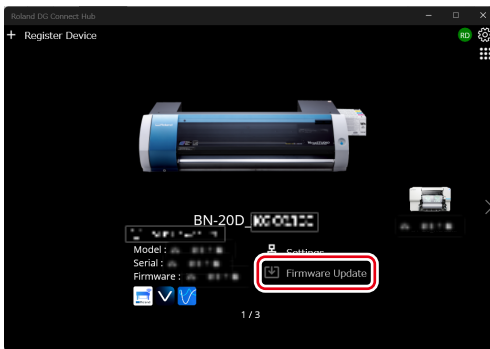

- 4 Click [Update].
- 5 Download the BN20Firm.zip file to the desired location.
- 6 Extract the files from BN20Firm.zip.
- 7 Run BN20Firm37*.exe in the BN20Firm folder.
- 8 Click [Next].

The new firmware will be installed.

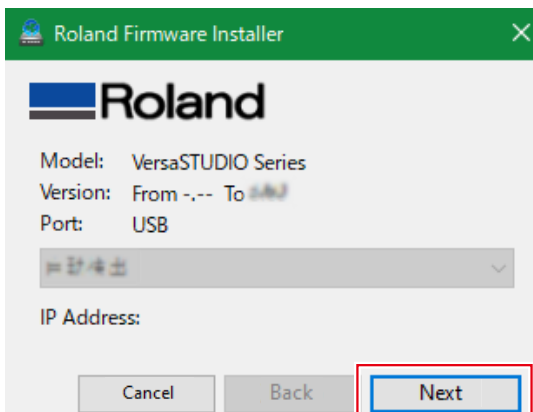

- 9 When the message "The installation of firmware was successful." appears, click [OK].
The update is complete if the firmware version is 3.7*. The machine will automatically restart.

Step 2: Downloading the BN-20D Driver and Utility Installer

Procedure

- 1 Access the following URL
<https://downloadcenter.rolanddg.com/BN-20D#software>
- 2 Click [Roland_DG_Software_Package_for_BN-20D].
- 3 Click [Installer [****_**_**, Ver. *.*.*]].
- 4 Carefully read the explanation on the screen, and then click [Next].
- 5 Carefully read the license agreement for the software, and then click [Agree].
- 6 Specify the folder in which to save the software, and then click [Save].
The download of [Roland_DG_Software_Package_for_BN-20D.zip] starts.

Step 3: Installing BN-20D Driver and Utility

Procedure

- 1 Double-click the extracted folder [Roland_DG_Software_Package_for_BN-20D].
- 2 Double-click [menu.exe].
- 3 Click [Install].
When the [User Account Control] window appears, click [Yes] (or [Allow]). The setup menu screen appears automatically.
- 4 Select the model name and the port to start setup.
 - ① Select [Install].
 - ② Select [Roland BN-20D] for [Model Name].
 - ③ Select [USB] for [Port].
 - ④ Click [Start].
- 5 Click [Next].
- 6 Follow the on-screen instructions to complete the installation of Driver and Utility.

Step 4: Checking the Firmware Version

Right-click the Utility taskbar and select [Version Information BN-20D Utility(A)...]. Check that the Utility version is 1.4* and firmware version is 3.7*.

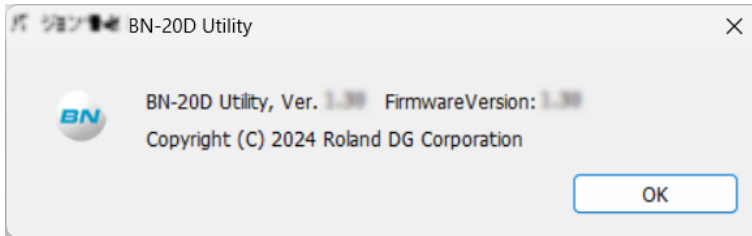

Step 5: Performing a Nozzle Drop-out Test

Procedure

- 1 Start Utility.
- 2 On the [Adjustment] tab, click [Check Nozzle Condition].
- 3 Click [Test Print].

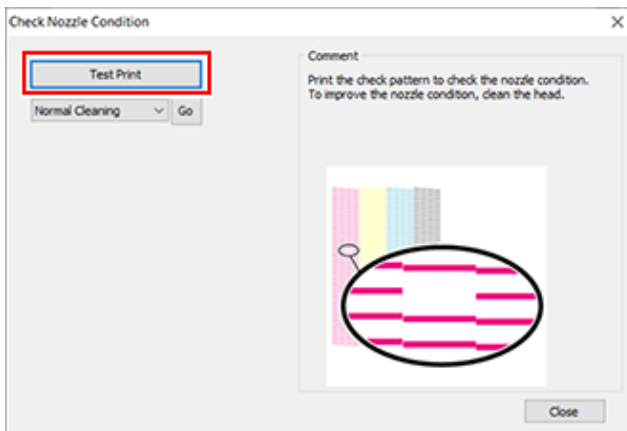

- 4 Check for multiple instances of dot drop-out in the test pattern.

Missing blocks indicate dot drop-out. Collapsed or inclined blocks indicate dot displacement.

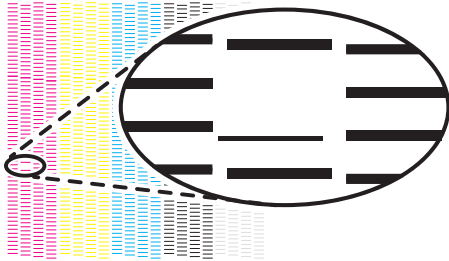

Does dot drop-out occur in multiple locations?

Yes > Proceed to Step 5.

No > Proceed to "Step 6: Replacing the Drain Cartridge."

MEMO

Switching to S-PG2 ink is possible if dot drop-out occurs in just a few locations. In such cases, proceed to "Step 6: Replacing the Drain Cartridge." If dot drop-out occurs in multiple locations within a row, cleaning is required. Proceed to Step 5.

- 5 If the nozzle drop-out test performed in Step 4 results in dot drop-out occurring in multiple locations, perform the following procedure.

MEMO

For (1) Manual Cleaning, use the current cleaning liquid instead of the S-PG2-CL cleaning liquid.

- ① Manual cleaning

https://downloadcenter.rolanddg.com/contents/manuals/BN-20D_USE_EN/index.html?id=fft1625633434484

- ② Medium cleaning

https://downloadcenter.rolanddg.com/contents/manuals/BN-20D_USE_EN/index.html?id=uyj1625633455150

- ③ Perform a nozzle drop-out test and check for multiple instances of dot drop-out.

Does dot drop-out occur in multiple locations?

Yes > Contact your authorized dealer.

No > Proceed to "Step 6: Replacing the Drain Cartridge."

Step 6: Replacing the Drain Cartridge

https://downloadcenter.rolanddg.com/contents/manuals/BN-20D_USE_EN/index.html?id=umg1625633454876

Step 7: Fill with S-PG2 ink.

Procedure

- 1 Remove all S-PG ink cartridges from the machine.

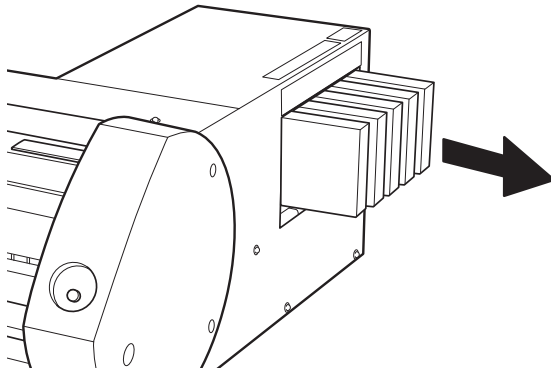

- 2 On the [Options] tab, click [Ink Draining].
- 3 Shake a new S-PG2 ink cartridge.

The precipitation of the ingredients in the ink disables printing in normal color. So that the ink mixes well, shake each ink cartridge 100 times (about 40 seconds) horizontally with a stroke length of around 5 cm (1.97 in.) from each end of the ink cartridge before inserting it.

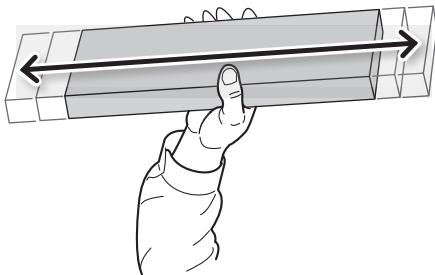

- 4 Insert the S-PG2 ink cartridge.
- 5 Click [Next].

Follow the instructions on the Utility screen to fill the ink.

Step 8: Replacing Parts for Maintenance

Procedure

1 On the [Replacement Tools] tab, click the [Execute] button for each of the following parts and follow the instructions on the Utility screen to replace the parts.

- Wiper
https://downloadcenter.rolanddg.com/contents/manuals/BN-20D_USE_EN/index.html?id=gzr1625633459396
- Felt wiper
https://downloadcenter.rolanddg.com/contents/manuals/BN-20D_USE_EN/index.html?id=ekv1625633460630
- Wiper pad
https://downloadcenter.rolanddg.com/contents/manuals/BN-20D_USE_EN/index.html?id=olf1706155789496

MEMO

Wiper pad replacement is not necessary in the following cases:

- If it has only been a short time since you last replaced the wiper pad
- If the wiper pad is not heavily soiled
- If you plan to replace the wiper pad after switching to S-PG2 ink

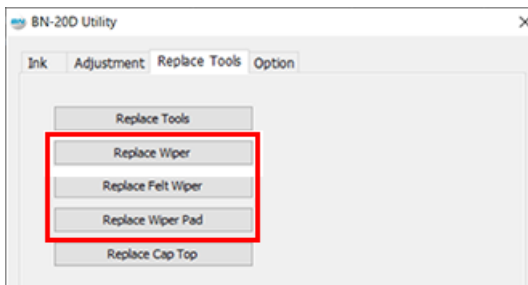

2 On the [Replacement Tools] tab, click [Cap Top Replacement] and follow the instructions on the Utility screen to replace the cap top.

MEMO

Use the following link to view a reference video for this procedure. We recommend that you view this video to understand the overall flow of work.

<https://www.youtube.com/watch?v=1eU9UKVuMS0>

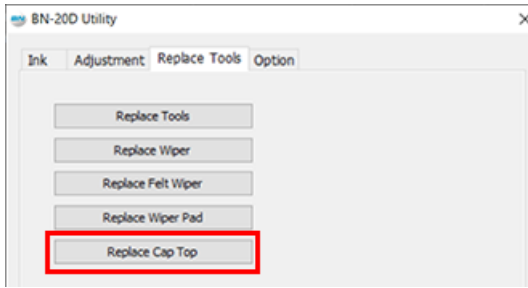

Step 9: Performing a Nozzle Drop-out Test

Procedure

- 1 On the [Adjustment] tab, click [Check Nozzle Condition].
- 2 Click [Test Print].

Printing of the test pattern starts.

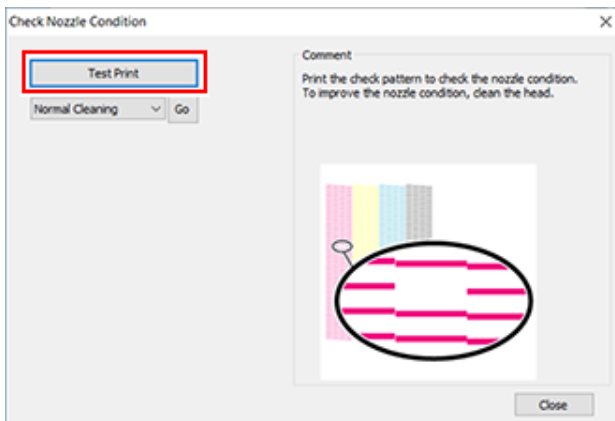

- 3 Check whether there is dot drop-out or dot displacement in the test pattern.

Missing blocks indicate dot drop-out. Collapsed or inclined blocks indicate dot displacement.

MEMO

It may be possible to ignore the effect on products if drop-out occurs in just a few locations. Try printing. If you can judge that the product is not affected, use the printer without any further cleaning.

If dot drop-out or dot displacement occurs in multiple locations, perform powerful cleaning multiple times.

https://downloadcenter.rolanddg.com/contents/manuals/BN-20D_USE_EN/index.html?id=uyj1625633455150

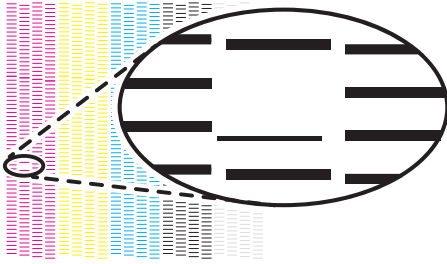

Use S-PG2-CL cleaning liquid after switching to S-PG2 ink. Also, be sure to perform Manual Cleaning at the end of each day's work.

Step 10: Registering the BN-20D in VersaWorks Again

If a BN-20D used before the ink was switched is registered in VersaWorks, the ink will not be recognized as S-PG2, making printing impossible due to an ink mismatch. To recognize the ink as S-PG2 and enable printing, delete the BN-20D model information from VersaWorks, and then register the BN-20D again.

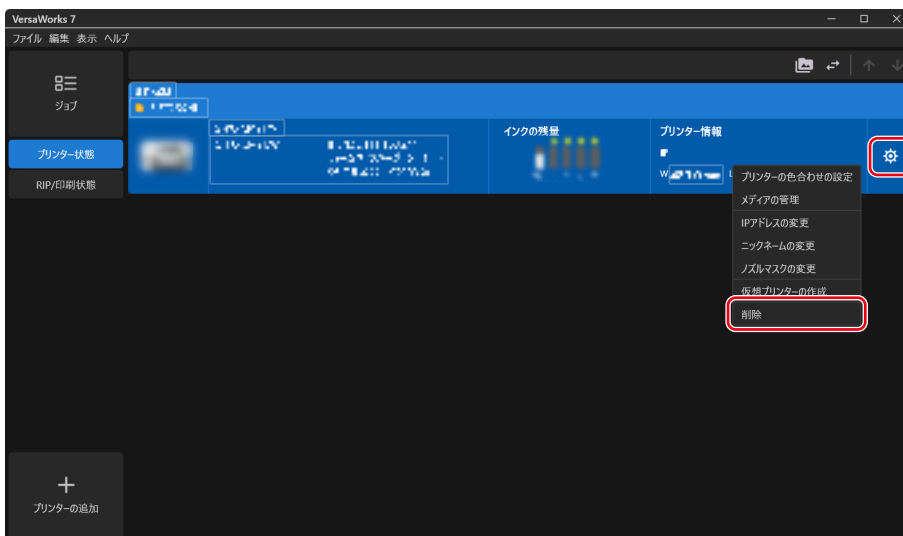

For the procedure for registering a printer in VersaWorks, refer to Steps 3 and later in the procedure accessed from the following link.

https://downloadcenter.rolanddg.com/contents/manuals/VW7_INS_EN/index.html?id=cez1732143725149

This completes the operations to switch to S-PG2 ink.

